

4

3

2

1

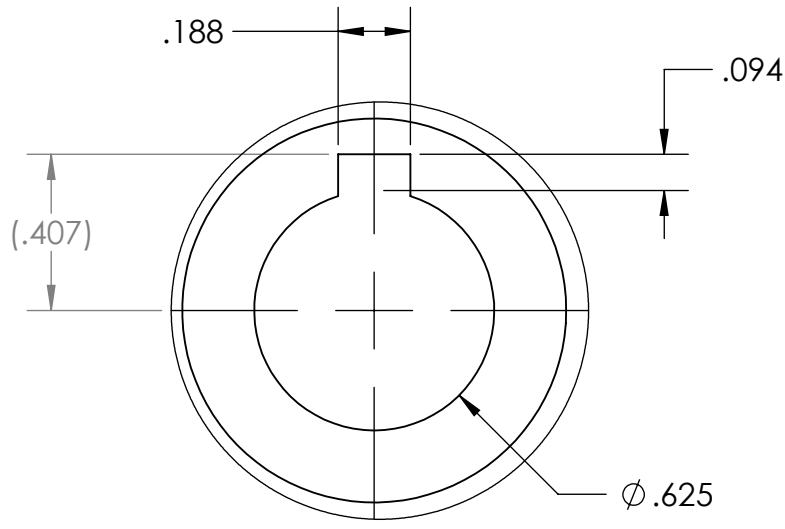

DETAIL B
SCALE 2:1

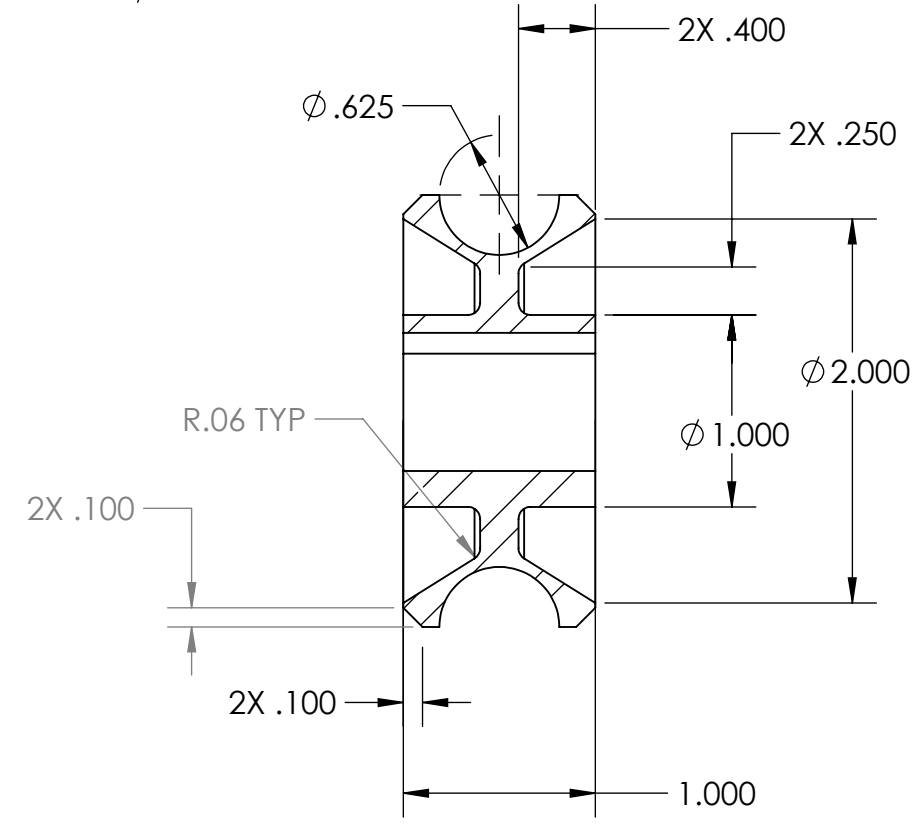
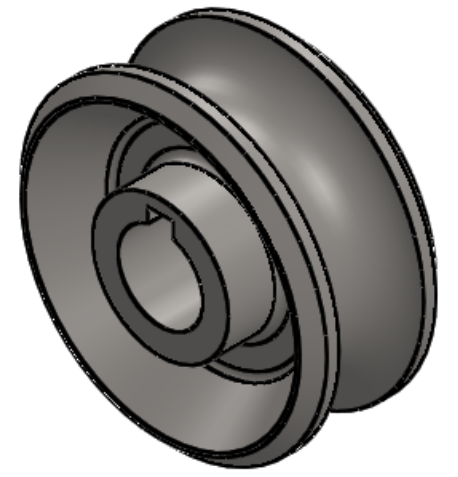
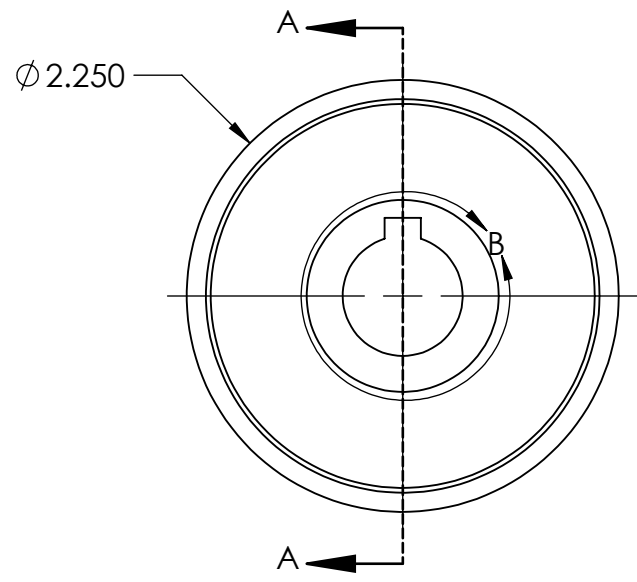

SECTION A-A

PROPRIETARY AND CONFIDENTIAL
 THE INFORMATION CONTAINED IN THIS DRAWING IS THE SOLE PROPERTY OF <INSERT COMPANY NAME HERE>. ANY REPRODUCTION IN PART OR AS A WHOLE WITHOUT THE WRITTEN PERMISSION OF <INSERT COMPANY NAME HERE> IS PROHIBITED.

		UNLESS OTHERWISE SPECIFIED:		NAME	DATE
		DIMENSIONS ARE IN INCHES TOLERANCES: FRACTIONAL ± ANGULAR: MACH ± 30' BEND ± TWO PLACE DECIMAL ± .02 THREE PLACE DECIMAL ± .010		DRAWN	
		INTERPRET GEOMETRIC TOLERANCING PER:		CHECKED	
		MATERIAL		ENG APPR.	
NEXT ASSY	USED ON	FINISH		MFG APPR.	
APPLICATION		DO NOT SCALE DRAWING		Q.A.	
				COMMENTS:	
TITLE: WORM GEAR					
SIZE	DWG. NO.	REV			
B	JB-MNT103				
SCALE: 1:1		WEIGHT:		SHEET 1 OF 1	

4

3

2

1

B

B

A

A